

Product Selector Guide

Part Number	Memory					Core				Timers						Serial Interfaces										Analog				5-V Tolerant GPIOs ^a	Battery-Backed Hibernation	LDO Voltage Regulator	Operating Temperature ^b	Package	Production (P) or Sampling (S)				
	Flash (KB)	SRAM (KB)	ROM Software Libraries	DMA	SAFERTOS™	Max Speed (MHz)	Internal Precision Oscillator	MPU	SysTick (24-bit)	General-Purpose	Real-Time Clock (RTC)	Watchdog	Motion Control				Ethernet		CAN MAC	USB D, H, or O ^c	UART	I ² C	SSI/SPI	I ² S	ADC Units	ADC			Internal Temp Sensor							Analog/Digital Comparators			
													PWM ^d	PWM Fault	Dead-Band Generator	CCP	QEI Channels	External Peripheral Interface								10/100 MAC+PHY	10/100 MAC with MII Interface	IEEE 1588									ADC Resolution (10- or 12-bit)	ADC Channels	ADC Speed (samples per second)
LM3S101	8	2	-	-	-	20	-	-	✓	2	✓	1	-	-	-	-	-	-	1	-	1	-	-	-	-	-	-	-	2/0	2-18	-	✓	I/E	28SOIC 48QFP 48QFN	P				
LM3S102	8	2	-	-	-	20	-	-	✓	2	✓	1	-	-	-	-	-	-	1	1	1	-	-	-	-	-	-	1/0	0-18	-	✓	I/E	28SOIC 48QFP 48QFN	P					
LM3S300	16	4	-	-	-	25	-	✓	✓	3	✓	1	-	-	-	-	-	-	2	1	1	-	-	-	-	-	-	3/0	8-36	-	✓	I/E	48QFP 48QFN	P					
LM3S301	16	2	-	-	-	20	-	✓	✓	2	✓	1	2	1	✓	2	-	-	1	-	1	-	1	10	3	250K	✓	2/0	12-33	-	✓	I/E	48QFP 48QFN	P					
LM3S308	16	4	-	-	-	25	-	✓	✓	3	✓	1	-	-	-	6	-	-	2	1	1	-	1	10	8	500K	✓	1/0	5-28	-	✓	I/E	48QFP 48QFN	P					
LM3S310	16	4	-	-	-	25	-	✓	✓	3	✓	1	6	1	✓	6	-	-	2	-	1	-	-	-	-	-	-	3/0	3-36	-	✓	I/E	48QFP 48QFN	P					
LM3S315	16	4	-	-	-	25	-	✓	✓	3	✓	1	2	1	✓	6	-	-	2	-	1	-	1	10	4	250K	✓	1/0	7-32	-	✓	I/E	48QFP 48QFN	P					
LM3S316	16	4	-	-	-	25	-	✓	✓	3	✓	1	4	1	✓	6	-	-	2	1	1	-	1	10	4	250K	✓	1/0	3-32	-	✓	I/E	48QFP 48QFN	P					
LM3S317	16	4	-	-	-	25	-	✓	✓	3	✓	1	6	1	✓	6	-	-	1	-	1	-	1	10	6	250K	✓	1/0	3-30	-	✓	I/E	48QFP 48QFN	P					
LM3S328	16	4	-	-	-	25	-	✓	✓	3	✓	1	-	-	-	6	-	-	2	1	1	-	1	10	8	500K	✓	0/0	7-28	-	✓	I/E	48QFP 48QFN	P					
LM3S600	32	8	-	-	-	50	-	✓	✓	3	✓	1	-	-	-	6	-	-	2	1	1	-	-	-	-	-	-	3/0	8-36	-	✓	I/E	48QFP 48QFN	P					

a. Minimum is number of pins dedicated to GPIO; additional pins are available if certain peripherals are not used. See data sheet for details.
 b. Industrial (I) temperature is -40 to +85 °C and Extended (E) temperature is -40 to +105 °C.
 c. USB options for Stellaris microcontrollers include Device Only (D) capability, Host/Device (H) capability, and On-The-Go/Host/Device capability (O).
 d. PWM motion-control functionality can be achieved through dedicated motion control hardware (the PWM pins) or through the motion control features of the general-purpose timers (the CCP pins). See data sheet for details.

Product Selector Guide (Continued)

Part Number	Memory					Core				Timers							Serial Interfaces										Analog					5-V Tolerant GPIOs ^a	Battery-Backed Hibernation	LDO Voltage Regulator	Operating Temperature ^b	Package	Production (P) or Sampling (S)		
	Flash (KB)	SRAM (KB)	ROM Software Libraries	DMA	SAFERTOS™	Max Speed (MHz)	Internal Precision Oscillator	MPU	SysTick (24-bit)	General-Purpose	Real-Time Clock (RTC)	Watchdog	Motion Control				Ethernet			CAN MAC	USB D, H, or O ^c	UART	I ² C	SSI/SPI	I ² S	ADC Units	ADC			Internal Temp Sensor	Analog/Digital Comparators								
													PWM ^d	PWM Fault	Dead-Band Generator	CCP	QEI Channels	External Peripheral Interface	10/100 MAC+PHY								10/100 MAC with MII Interface	IEEE 1588	ADC Resolution (10- or 12-bit)									ADC Channels	ADC Speed (samples per second)
LM3S601	32	8	-	-	-	50	-	✓	✓	3	✓	1	6	1	✓	6	1	-	-	-	-	-	2	1	1	-	-	-	-	-	3/0	0-36	-	✓	I/E	48QFP 48QFN	P		
LM3S608	32	8	-	-	-	50	-	✓	✓	3	✓	1	-	-	-	6	-	-	-	-	-	-	2	1	1	-	1	10	8	500K	✓	1/0	5-28	-	✓	I/E	48QFP 48QFN	P	
LM3S610	32	8	-	-	-	50	-	✓	✓	3	✓	1	6	1	✓	6	-	-	-	-	-	-	2	1	1	-	1	10	2	500K	✓	0/0	6-34	-	✓	I/E	48QFP 48QFN	P	
LM3S611	32	8	-	-	-	50	-	✓	✓	3	✓	1	6	1	✓	6	-	-	-	-	-	-	2	1	1	-	1	10	4	500K	✓	0/0	4-32	-	✓	I/E	48QFP 48QFN	P	
LM3S612	32	8	-	-	-	50	-	✓	✓	3	✓	1	2	1	✓	6	-	-	-	-	-	-	2	1	1	-	1	10	2	500K	✓	1/0	7-34	-	✓	I/E	48QFP 48QFN	P	
LM3S613	32	8	-	-	-	50	-	✓	✓	3	✓	1	4	1	✓	6	-	-	-	-	-	-	2	1	1	-	1	10	4	500K	✓	1/0	3-32	-	✓	I/E	48QFP 48QFN	P	
LM3S615	32	8	-	-	-	50	-	✓	✓	3	✓	1	6	1	✓	6	-	-	-	-	-	-	2	1	1	-	1	10	2	500K	✓	3/0	0-34	-	✓	I/E	48QFP 48QFN	P	
LM3S617	32	8	-	-	-	50	-	✓	✓	3	✓	1	6	1	✓	6	-	-	-	-	-	-	2	-	1	-	1	10	6	500K	✓	1/0	1-30	-	✓	I/E	48QFP 48QFN	P	
LM3S618	32	8	-	-	-	50	-	✓	✓	3	✓	1	6	1	✓	4	1	-	-	-	-	-	2	-	1	-	1	10	6	500K	✓	1/0	0-30	-	✓	I/E	48QFP 48QFN	P	
LM3S628	32	8	-	-	-	50	-	✓	✓	3	✓	1	-	-	-	4	-	-	-	-	-	-	2	1	1	-	1	10	8	1M	✓	0/0	9-28	-	✓	I/E	48QFP 48QFN	P	
LM3S800	64	8	-	-	-	50	-	✓	✓	3	✓	1	-	-	-	6	-	-	-	-	-	-	2	1	1	-	-	-	-	-	3/0	8-36	-	✓	I/E	48QFP 48QFN	P		
LM3S801	64	8	-	-	-	50	-	✓	✓	3	✓	1	6	1	✓	6	1	-	-	-	-	-	2	1	1	-	-	-	-	-	3/0	0-36	-	✓	I/E	48QFP 48QFN	P		

a. Minimum is number of pins dedicated to GPIO; additional pins are available if certain peripherals are not used. See data sheet for details.

b. Industrial (I) temperature is -40 to +85 °C and Extended (E) temperature is -40 to +105 °C.

c. USB options for Stellaris microcontrollers include Device Only (D) capability, Host/Device (H) capability, and On-The-Go/Host/Device capability (O).

d. PWM motion-control functionality can be achieved through dedicated motion control hardware (the PWM pins) or through the motion control features of the general-purpose timers (the CCP pins). See data sheet for details.

Product Selector Guide (Continued)

Part Number	Memory					Core				Timers							Serial Interfaces										Analog					5-V Tolerant GPIOs ^a	Battery-Backed Hibernation	LDO Voltage Regulator	Operating Temperature ^b	Package	Production (P) or Sampling (S)		
	Flash (KB)	SRAM (KB)	ROM Software Libraries	DMA	SAFERTOS™	Max Speed (MHz)	Internal Precision Oscillator	MPU	SysTick (24-bit)	General-Purpose	Real-Time Clock (RTC)	Watchdog	Motion Control				Ethernet			CAN MAC	USB D, H, or O ^c	UART	I ² C	SSI/SPI	I ² S	ADC			Internal Temp Sensor	Analog/Digital Comparators									
													PWM ^d	PWM Fault	Dead-Band Generator	CCP	QEI Channels	External Peripheral Interface	10/100 MAC+PHY							10/100 MAC with MII Interface	IEEE 1588	ADC Units			ADC Resolution (10- or 12-bit)							ADC Channels	ADC Speed (samples per second)
LM3S808	64	8	-	-	-	50	-	✓	✓	3	✓	1	-	-	-	-	-	-	-	-	2	1	1	-	1	10	8	500K	✓	1/0	5-28	-	✓	I/E	48QFP 48QFN	P			
LM3S811	64	8	-	-	-	50	-	✓	✓	3	✓	1	6	1	✓	6	-	-	-	-	2	1	1	-	1	10	4	500K	✓	1/0	1-32	-	✓	I/E	48QFP 48QFN	P			
LM3S812	64	8	-	-	-	50	-	✓	✓	3	✓	1	2	1	✓	6	-	-	-	-	2	1	1	-	1	10	2	250K	✓	1/0	7-34	-	✓	I/E	48QFP 48QFN	P			
LM3S815	64	8	-	-	-	50	-	✓	✓	3	✓	1	6	1	✓	6	-	-	-	-	2	1	1	-	1	10	2	500K	✓	3/0	0-34	-	✓	I/E	48QFP 48QFN	P			
LM3S817	64	8	-	-	-	50	-	✓	✓	3	✓	1	6	1	✓	6	-	-	-	-	2	-	1	-	1	10	6	1M	✓	1/0	1-30	-	✓	I/E	48QFP 48QFN	P			
LM3S818	64	8	-	-	-	50	-	✓	✓	3	✓	1	6	1	✓	4	1	-	-	-	2	-	1	-	1	10	6	1M	✓	1/0	0-30	-	✓	I/E	48QFP 48QFN	P			
LM3S828	64	8	-	-	-	50	-	✓	✓	3	✓	1	-	-	-	6	-	-	-	-	2	1	1	-	1	10	8	1M	✓	0/0	7-28	-	✓	I/E	48QFP 48QFN	P			
LM3S1110	64	16	-	-	-	25	-	✓	✓	3	✓	1	-	-	-	2	-	-	-	-	2	-	1	-	-	-	-	-	-	2/0	20-41	✓	✓	I/E	100LQFP 108BGA	P			
LM3S1133	64	16	-	-	-	50	-	✓	✓	4	✓	1	2	1	✓	8	-	-	-	-	3	1	2	-	1	10	2	250K	✓	1/0	9-44	✓	✓	I/E	100LQFP 108BGA	P			
LM3S1138	64	16	-	-	-	50	-	✓	✓	4	✓	1	-	-	-	6	-	-	-	-	3	2	2	-	1	10	8	1M	✓	3/0	9-46	✓	✓	I/E	100LQFP 108BGA	P			
LM3S1150	64	16	-	-	-	50	-	✓	✓	4	✓	1	6	1	✓	6	1	-	-	-	3	1	2	-	-	-	-	-	-	3/0	7-52	✓	✓	I/E	100LQFP 108BGA	P			
LM3S1162	64	16	-	-	-	50	-	✓	✓	4	✓	1	6	1	✓	6	-	-	-	-	3	1	2	-	1	10	2	500K	✓	3/0	4-46	✓	✓	I/E	100LQFP 108BGA	P			

a. Minimum is number of pins dedicated to GPIO; additional pins are available if certain peripherals are not used. See data sheet for details.
 b. Industrial (I) temperature is -40 to +85 °C and Extended (E) temperature is -40 to +105 °C.
 c. USB options for Stellaris microcontrollers include Device Only (D) capability, Host/Device (H) capability, and On-The-Go/Host/Device capability (O).
 d. PWM motion-control functionality can be achieved through dedicated motion control hardware (the PWM pins) or through the motion control features of the general-purpose timers (the CCP pins). See data sheet for details.

Product Selector Guide (Continued)

Part Number	Memory					Core				Timers							Serial Interfaces										Analog					5-V Tolerant GPIOs ^a	Battery-Backed Hibernation	LDO Voltage Regulator ^b	Operating Temperature ^b	Package	Production (P) or Sampling (S)		
	Flash (KB)	SRAM (KB)	ROM Software Libraries	DMA	SAFERTOS™	Max Speed (MHz)	Internal Precision Oscillator	MPU	SysTick (24-bit)	General-Purpose	Real-Time Clock (RTC)	Watchdog	Motion Control					Ethernet		CAN MAC	USB D, H, or O ^c	UART	I ² C	SSI/SPI	I ² S	ADC Units	ADC			Internal Temp Sensor	Analog/Digital Comparators								
													PWM ^d	PWM Fault	Dead-Band Generator	CCP	QEI Channels	External Peripheral Interface	10/100 MAC+PHY								10/100 MAC with MII Interface	IEEE 1588	ADC Resolution (10- or 12-bit)									ADC Channels	ADC Speed (samples per second)
LM3S1165	64	16	-	-	-	50	-	✓	✓	4	✓	1	6	1	✓	8	-	-	-	-	-	3	1	2	-	1	10	4	500K	✓	1/0	4-43	✓	✓	I/E	100LQFP 108BGA	P		
LM3S1166	64	16	-	-	-	50	-	✓	✓	4	✓	1	6	1	✓	8	-	-	-	-	-	3	1	2	-	1	10	4	500K	✓	1/0	4-43	✓	✓	I	100LQFP	P		
LM3S1332	96	16	-	-	-	50	-	✓	✓	4	✓	1	-	-	-	8	-	-	-	-	-	2	-	1	-	1	10	3	250K	✓	3/0	29-57	✓	✓	I/E	100LQFP 108BGA	P		
LM3S1435	96	32	-	-	-	50	-	✓	✓	3	✓	1	2	1	✓	4	-	-	-	-	-	2	1	1	-	1	10	2	500K	✓	1/0	21-46	✓	✓	I/E	100LQFP 108BGA	P		
LM3S1439	96	32	-	-	-	50	-	✓	✓	3	✓	1	6	1	✓	6	1	-	-	-	-	2	1	2	-	1	10	4	500K	✓	1/0	14-52	✓	✓	I/E	100LQFP 108BGA	P		
LM3S1512	96	64	-	-	-	25	-	✓	✓	4	✓	1	-	-	-	8	1	-	-	-	-	3	2	2	-	1	10	2	250K	✓	3/0	15-58	✓	✓	I/E	100LQFP 108BGA	P		
LM3S1538	96	64	-	-	-	50	-	✓	✓	4	✓	1	-	-	-	8	1	-	-	-	-	3	2	2	-	1	10	8	500K	✓	0/0	9-43	✓	✓	I/E	100LQFP 108BGA	P		
LM3S1601	128	32	-	-	-	50	-	✓	✓	4	✓	1	-	-	-	8	-	-	-	-	-	3	2	2	-	-	-	-	-	2/0	23-60	✓	✓	I/E	100LQFP 108BGA	P			
LM3S1607	128	32	✓	✓	-	50	-	✓	✓	4	✓	1	-	-	-	6	-	-	-	-	-	3	2	1	-	1	10	8	500K	✓	0/0	0-33	✓	✓	I	64LQFP	P		
LM3S1608	128	32	-	-	-	50	-	✓	✓	4	✓	1	-	-	-	8	-	-	-	-	-	2	2	2	-	1	10	8	500K	✓	2/0	17-52	✓	✓	I/E	100LQFP 108BGA	P		
LM3S1620	128	32	-	-	-	25	-	✓	✓	3	✓	1	6	1	✓	4	1	-	-	-	-	2	1	2	-	-	-	-	-	3/0	11-52	✓	✓	I/E	100LQFP 108BGA	P			
LM3S1621	128	32	✓	✓	-	80	✓	✓	✓	4	✓	2	-	-	-	8	-	✓	-	-	-	3	2	2	-	1	10	8	1M	✓	2/8	0-67	✓	✓	I	100LQFP 108BGA	S		
LM3S1625	128	32	✓	✓	-	50	-	✓	✓	4	✓	1	4	1	✓	4	-	-	-	-	-	1	2	1	-	1	10	6	500K	✓	1/0	0-33	-	✓	I	64LQFP	P		
LM3S1626	128	32	✓	✓	-	50	-	✓	✓	4	✓	1	4	1	✓	4	1	-	-	-	-	2	1	1	-	1	10	6	500K	✓	0/0	0-33	-	✓	I	64LQFP	P		

a. Minimum is number of pins dedicated to GPIO; additional pins are available if certain peripherals are not used. See data sheet for details.

b. Industrial (I) temperature is -40 to +85 °C and Extended (E) temperature is -40 to +105 °C.

c. USB options for Stellaris microcontrollers include Device Only (D) capability, Host/Device (H) capability, and On-The-Go/Host/Device capability (O).

d. PWM motion-control functionality can be achieved through dedicated motion control hardware (the PWM pins) or through the motion control features of the general-purpose timers (the CCP pins). See data sheet for details.

Product Selector Guide (Continued)

Part Number	Memory					Core				Timers						Serial Interfaces										Analog				5-V Tolerant GPIOs ^a	Battery-Backed Hibernation	LDO Voltage Regulator	Operating Temperature ^b	Package	Production (P) or Sampling (S)				
	Flash (KB)	SRAM (KB)	ROM Software Libraries	DMA	SAFERTOS™	Max Speed (MHz)	Internal Precision Oscillator	MPU	SysTick (24-bit)	General-Purpose	Real-Time Clock (RTC)	Motion Control					Ethernet					ADC																	
												Watchdog	PWM ^d	PWM Fault	Dead-Band Generator	CCP	QEI Channels	External Peripheral Interface	10/100 MAC+PHY	10/100 MAC with MII Interface	IEEE 1588	CAN MAC	USB D, H, or O ^c	UART	I ² C	SSI/SPI	I ² S	ADC Units	ADC Resolution (10- or 12-bit)							ADC Channels	ADC Speed (samples per second)	Internal Temp Sensor	Analog/Digital Comparators
LM3S1627	128	32	✓	✓	-	50	-	✓	✓	4	✓	1	6	1	✓	4	1	-	-	-	-	-	2	1	1	-	1	10	4	500K	✓	0/0	0-33	-	✓	I	64LQFP	P	
LM3S1635	128	32	-	-	-	50	-	✓	✓	4	✓	1	6	1	✓	8	-	-	-	-	-	-	3	2	2	-	1	10	4	500K	✓	2/0	12-56	✓	✓	I/E	100LQFP 108BGA	P	
LM3S1636	128	32	-	-	-	50	-	✓	✓	4	✓	1	6	1	✓	8	-	-	-	-	-	-	3	2	2	-	1	10	4	500K	✓	2/0	12-56	✓	✓	I	100LQFP	P	
LM3S1637	128	32	-	-	-	50	-	✓	✓	4	✓	1	6	1	✓	6	1	-	-	-	-	-	3	1	1	-	1	10	4	1M	✓	1/0	7-43	✓	✓	I/E	100LQFP 108BGA	P	
LM3S1651	128	32	✓	✓	-	80	✓	✓	✓	4	✓	2	6	4	✓	8	2	-	-	-	-	-	3	2	2	✓	2	10	16	1M	✓	2/16	0-67	✓	✓	I	100LQFP 108BGA	S	
LM3S1751	128	64	-	-	-	50	-	✓	✓	3	✓	1	4	1	✓	6	-	-	-	-	-	-	3	1	2	-	1	10	4	500K	✓	1/0	21-56	✓	✓	I/E	100LQFP 108BGA	P	
LM3S1776	128	64	✓	✓	-	50	-	✓	✓	3	✓	1	8	3	✓	2	-	-	-	-	-	-	1	1	1	-	1	10	6	1M	✓	0/0	1-33	✓	✓	I	64LQFP	P	
LM3S1811	256	32	✓	✓	-	50	✓	✓	✓	4	✓	2	-	-	-	8	-	✓	-	-	-	-	3	2	2	-	1	10	8	1M	✓	2/8	0-67	✓	✓	I	100LQFP 108BGA	S	
LM3S1816	256	32	✓	✓	-	50	✓	✓	✓	4	✓	2	-	-	-	8	-	-	-	-	-	-	3	2	2	-	1	10	8	1M	✓	2/8	0-33	✓	✓	I	64LQFP	S	
LM3S1850	256	32	-	-	-	50	-	✓	✓	3	✓	1	6	1	✓	6	1	-	-	-	-	-	2	1	1	-	-	-	-	-	-	3/0	17-56	✓	✓	I/E	100LQFP 108BGA	P	
LM3S1911	256	64	-	-	-	50	-	✓	✓	4	✓	1	-	-	-	8	-	-	-	-	-	-	3	2	2	-	-	-	-	-	-	2/0	23-60	✓	✓	I/E	100LQFP 108BGA	P	
LM3S1918	256	64	-	-	-	50	-	✓	✓	4	✓	1	-	-	-	8	-	-	-	-	-	-	2	2	2	-	1	10	8	500K	✓	2/0	17-52	✓	✓	I/E	100LQFP 108BGA	P	
LM3S1937	256	64	-	-	-	50	-	✓	✓	3	✓	1	6	1	✓	4	-	-	-	-	-	-	2	1	1	-	1	10	4	1M	✓	1/0	27-56	✓	✓	I/E	100LQFP 108BGA	P	
LM3S1958	256	64	-	-	-	50	-	✓	✓	4	✓	1	-	-	-	8	-	-	-	-	-	-	3	2	2	-	1	10	8	1M	✓	0/0	21-52	✓	✓	I/E	100LQFP 108BGA	P	

a. Minimum is number of pins dedicated to GPIO; additional pins are available if certain peripherals are not used. See data sheet for details.

b. Industrial (I) temperature is -40 to +85 °C and Extended (E) temperature is -40 to +105 °C.

c. USB options for Stellaris microcontrollers include Device Only (D) capability, Host/Device (H) capability, and On-The-Go/Host/Device capability (O).

d. PWM motion-control functionality can be achieved through dedicated motion control hardware (the PWM pins) or through the motion control features of the general-purpose timers (the CCP pins). See data sheet for details.

Product Selector Guide (Continued)

Part Number	Memory					Core				Timers							Serial Interfaces										Analog					5-V Tolerant GPIOs ^a	Battery-Backed Hibernation	LDO Voltage Regulator	Operating Temperature ^b	Package	Production (P) or Sampling (S)		
	Flash (KB)	SRAM (KB)	ROM Software Libraries	DMA	SAFERTOS™	Max Speed (MHz)	Internal Precision Oscillator	MPU	SysTick (24-bit)	General-Purpose	Real-Time Clock (RTC)	Watchdog	Motion Control					Ethernet					ADC																
													PWM ^d	PWM Fault	Dead-Band Generator	CCP	QEI Channels	External Peripheral Interface	10/100 MAC+PHY	10/100 MAC with MII Interface	IEEE 1588	CAN MAC	USB D, H, or O ^c	UART	I ² C	SSI/SPI	I ² S	ADC Units	ADC Resolution (10- or 12-bit)	ADC Channels	ADC Speed (samples per second)							Internal Temp Sensor	Analog/Digital Comparators
LM3S1960	256	64	-	-	-	50	-	✓	✓	4	✓	1	6	1	✓	4	2	-	-	-	-	-	3	2	2	-	-	-	-	-	3/0	7-60	✓	✓	I/E	100LQFP 108BGA	P		
LM3S1968	256	64	-	-	-	50	-	✓	✓	4	✓	1	6	1	✓	4	2	-	-	-	-	-	3	2	2	-	1	10	8	1M	✓	3/0	5-52	✓	✓	I/E	100LQFP 108BGA	P	
LM3S1969	256	64	-	-	-	50	-	✓	✓	4	✓	1	6	1	✓	4	2	-	-	-	-	-	3	2	2	-	1	10	8	1M	✓	3/0	5-52	✓	✓	I	100LQFP	P	
LM3S1B21	256	96	✓	✓	-	80	✓	✓	✓	4	✓	2	-	-	-	8	-	✓	-	-	-	-	3	2	2	-	1	10	8	1M	✓	2/8	0-67	✓	✓	I	100LQFP 108BGA	S	
LM3S1C21	512	64	✓	✓	-	80	✓	✓	✓	4	✓	2	-	-	-	8	-	✓	-	-	-	-	3	2	2	-	1	12	8	1M	✓	2/8	0-67	✓	✓	I	100LQFP 108BGA	S	
LM3S1C26	512	64	✓	✓	-	80	✓	✓	✓	4	✓	2	-	-	-	8	-	-	-	-	-	-	3	2	2	-	1	12	8	1M	✓	2/8	0-33	✓	✓	I	64LQFP	S	
LM3S1C58	512	64	✓	✓	-	80	✓	✓	✓	4	✓	2	-	-	-	8	-	-	-	-	-	-	3	2	2	-	2	12	16	1M	✓	0/16	0-60	✓	✓	I	100LQFP 108BGA	S	
LM3S1D21	512	96	✓	✓	-	80	✓	✓	✓	4	✓	2	-	-	-	8	-	✓	-	-	-	-	3	2	2	-	1	12	8	1M	✓	2/8	0-67	✓	✓	I	100LQFP 108BGA	S	
LM3S1D26	512	96	✓	✓	-	80	✓	✓	✓	4	✓	2	-	-	-	8	-	-	-	-	-	-	3	2	2	-	1	12	8	1M	✓	2/8	0-33	✓	✓	I	64LQFP	S	
LM3S1F11	384	48	✓	✓	-	80	✓	✓	✓	4	✓	2	-	-	-	8	-	✓	-	-	-	-	3	2	2	-	1	12	8	1M	✓	2/8	0-67	✓	✓	I	100LQFP 108BGA	S	
LM3S1F16	384	48	✓	✓	-	80	✓	✓	✓	4	✓	2	-	-	-	8	-	-	-	-	-	-	3	2	2	-	1	12	8	1M	✓	2/8	0-33	✓	✓	I	64LQFP	S	
LM3S1G21	384	64	✓	✓	-	80	✓	✓	✓	4	✓	2	-	-	-	8	-	✓	-	-	-	-	3	2	2	-	1	12	8	1M	✓	2/8	0-67	✓	✓	I	100LQFP 108BGA	S	
LM3S1G58	384	64	✓	✓	-	80	✓	✓	✓	4	✓	2	-	-	-	8	-	-	-	-	-	-	3	2	2	-	2	12	16	1M	✓	0/16	0-60	✓	✓	I	100LQFP 108BGA	S	
LM3S1H11	512	48	✓	✓	-	80	✓	✓	✓	4	✓	2	-	-	-	8	-	✓	-	-	-	-	3	2	2	-	1	12	8	1M	✓	2/8	0-67	✓	✓	I	100LQFP 108BGA	S	

a. Minimum is number of pins dedicated to GPIO; additional pins are available if certain peripherals are not used. See data sheet for details.
 b. Industrial (I) temperature is -40 to +85 °C and Extended (E) temperature is -40 to +105 °C.
 c. USB options for Stellaris microcontrollers include Device Only (D) capability, Host/Device (H) capability, and On-The-Go/Host/Device capability (O).
 d. PWM motion-control functionality can be achieved through dedicated motion control hardware (the PWM pins) or through the motion control features of the general-purpose timers (the CCP pins). See data sheet for details.

Product Selector Guide (Continued)

Part Number	Memory					Core				Timers							Serial Interfaces										Analog					5-V Tolerant GPIOs ^a	Battery-Backed Hibernation	LDO Voltage Regulator	Operating Temperature ^b	Package	Production (P) or Sampling (S)		
	Flash (KB)	SRAM (KB)	ROM Software Libraries	DMA	SAFERTOS™	Max Speed (MHz)	Internal Precision Oscillator	MPU	SysTick (24-bit)	General-Purpose	Real-Time Clock (RTC)	Watchdog	Motion Control					Ethernet					ADC																
													PWM ^d	PWM Fault	Dead-Band Generator	CCP	QEI Channels	External Peripheral Interface	10/100 MAC+PHY	10/100 MAC with MII Interface	IEEE 1588	CAN MAC	USB D, H, or O ^c	UART	I ² C	SSI/SPI	I ² S	ADC Units	ADC Resolution (10- or 12-bit)	ADC Channels	ADC Speed (samples per second)							Internal Temp Sensor	Analog/Digital Comparators
LM3S1H16	512	48	✓	✓	-	80	✓	✓	✓	4	✓	2	-	-	-	8	-	-	-	-	-	3	2	2	-	1	12	8	1M	✓	2/8	0-33	✓	✓	I	64LQFP	S		
LM3S1J11	128	20	✓	✓	-	50	✓	✓	✓	3	✓	2	-	-	-	6	-	-	-	-	-	3	2	2	-	1	10	8	1M	✓	2/8	0-67	✓	✓	I	100LQFP 108BGA	S		
LM3S1J16	128	20	✓	✓	-	50	✓	✓	✓	3	✓	2	-	-	-	6	-	-	-	-	-	3	2	2	-	1	10	8	1M	✓	2/8	0-33	✓	✓	I	64LQFP	S		
LM3S1N11	64	12	✓	✓	-	50	✓	✓	✓	3	✓	2	-	-	-	6	-	-	-	-	-	3	2	2	-	1	10	8	1M	✓	2/8	0-67	✓	✓	I	100LQFP 108BGA	S		
LM3S1N16	64	12	✓	✓	-	50	✓	✓	✓	3	✓	2	-	-	-	6	-	-	-	-	-	3	2	2	-	1	10	8	1M	✓	2/8	0-33	✓	✓	I	64LQFP	S		
LM3S1P51	64	24	✓	✓	-	80	✓	✓	✓	4	✓	2	6	4	✓	8	2	-	-	-	-	3	2	2	✓	2	10	16	1M	✓	2/16	0-67	✓	✓	I	100LQFP 108BGA	S		
LM3S1R21	256	48	✓	✓	-	80	✓	✓	✓	4	✓	2	-	-	-	8	-	✓	-	-	-	3	2	2	-	1	10	8	1M	✓	2/8	0-67	✓	✓	I	100LQFP 108BGA	S		
LM3S1R26	256	48	✓	✓	-	80	✓	✓	✓	4	✓	2	-	-	-	8	-	-	-	-	-	3	2	2	-	1	10	8	1M	✓	2/8	0-33	✓	✓	I	64LQFP	S		
LM3S1W16	32	8	✓	✓	-	50	✓	✓	✓	3	✓	2	-	-	-	6	-	-	-	-	-	3	2	2	-	1	10	8	1M	✓	2/8	0-33	✓	✓	I	64LQFP	S		
LM3S1Z16	16	6	✓	✓	-	50	✓	✓	✓	3	✓	2	-	-	-	6	-	-	-	-	-	3	2	2	-	1	10	8	1M	✓	2/8	0-33	✓	✓	I	64LQFP	S		
LM3S2110	64	16	-	-	-	25	-	✓	✓	3	✓	1	2	1	✓	4	-	-	-	-	1	-	1	1	-	-	-	-	-	-	3/0	11-40	-	✓	I/E	100LQFP 108BGA	P		
LM3S2139	64	16	-	-	-	25	-	✓	✓	3	✓	1	-	-	-	6	-	-	-	-	1	-	2	1	1	-	1	10	4	250K	✓	3/0	26-56	-	✓	I/E	100LQFP 108BGA	P	
LM3S2276	64	32	✓	✓	-	50	-	✓	✓	3	✓	1	8	3	✓	1	-	-	-	-	1	-	1	1	-	1	10	6	1M	✓	0/0	0-33	✓	✓	I	64LQFP	P		
LM3S2410	96	32	-	-	-	25	-	✓	✓	3	✓	1	-	-	-	4	-	-	-	-	1	-	1	-	-	-	-	-	-	-	2/0	37-60	-	✓	I/E	100LQFP 108BGA	P		
LM3S2412	96	32	-	-	-	25	-	✓	✓	3	✓	1	2	1	✓	4	-	-	-	-	1	-	2	1	1	-	1	10	3	250K	✓	2/0	20-49	-	✓	I/E	100LQFP 108BGA	P	

a. Minimum is number of pins dedicated to GPIO; additional pins are available if certain peripherals are not used. See data sheet for details.

b. Industrial (I) temperature is -40 to +85 °C and Extended (E) temperature is -40 to +105 °C.

c. USB options for Stellaris microcontrollers include Device Only (D) capability, Host/Device (H) capability, and On-The-Go/Host/Device capability (O).

d. PWM motion-control functionality can be achieved through dedicated motion control hardware (the PWM pins) or through the motion control features of the general-purpose timers (the CCP pins). See data sheet for details.

Product Selector Guide (Continued)

Part Number	Memory					Core				Timers							Serial Interfaces										Analog					5-V Tolerant GPIOs ^a	Battery-Backed Hibernation	LDO Voltage Regulator ^b	Operating Temperature ^b	Package	Production (P) or Sampling (S)		
	Flash (KB)	SRAM (KB)	ROM Software Libraries	DMA	SAFERTOS™	Max Speed (MHz)	Internal Precision Oscillator	MPU	SysTick (24-bit)	General-Purpose	Real-Time Clock (RTC)	Watchdog	Motion Control				Ethernet			CAN MAC	USB D, H, or O ^c	UART	I ² C	SSI/SPI	I ² S	ADC Units	ADC			Internal Temp Sensor	Analog/Digital Comparators								
													PWM ^d	PWM Fault	Dead-Band Generator	CCP	QEI Channels	External Peripheral Interface	10/100 MAC+PHY								10/100 MAC with MII Interface	IEEE 1588	ADC Resolution (10- or 12-bit)									ADC Channels	ADC Speed (samples per second)
LM3S2432	96	32	-	-	-	50	-	✓	✓	3	✓	1	2	1	✓	4	-	-	-	-	-	1	-	2	1	1	-	1	10	3	250K	✓	2/0	5-34	-	✓	I/E	100LQFP 108BGA	P
LM3S2533	96	64	-	-	-	50	-	✓	✓	4	✓	1	6	1	✓	6	-	-	-	-	-	1	-	2	1	1	-	1	10	3	250K	✓	3/0	11-48	✓	✓	I/E	100LQFP 108BGA	P
LM3S2601	128	32	-	-	-	50	-	✓	✓	4	✓	1	-	-	-	8	-	-	-	-	-	1	-	3	2	2	-	-	-	-	-	2/0	21-60	✓	✓	I/E	100LQFP 108BGA	P	
LM3S2608	128	32	-	-	-	50	-	✓	✓	4	✓	1	-	-	-	8	-	-	-	-	-	1	-	2	2	2	-	1	10	8	500K	✓	2/0	15-52	✓	✓	I/E	100LQFP 108BGA	P
LM3S2616	128	16	✓	✓	-	50	-	✓	✓	4	-	1	6	1	✓	-	1	-	-	-	-	1	-	1	1	-	-	1	10	6	1M	✓	2/0	1-33	✓	✓	I	64LQFP	P
LM3S2620	128	32	-	-	-	25	-	✓	✓	4	✓	1	4	1	✓	6	1	-	-	-	-	2	-	1	1	1	-	-	-	-	-	3/0	12-52	✓	✓	I/E	100LQFP 108BGA	P	
LM3S2637	128	32	-	-	-	50	-	✓	✓	4	✓	1	-	-	-	6	-	-	-	-	-	1	-	2	1	1	-	1	10	4	500K	✓	3/0	15-46	✓	✓	I/E	100LQFP 108BGA	P
LM3S2651	128	32	-	-	-	50	-	✓	✓	4	✓	1	4	1	✓	6	-	-	-	-	-	1	-	3	1	2	-	1	10	4	500K	✓	1/0	16-53	✓	✓	I/E	100LQFP 108BGA	P
LM3S2671	128	32	✓	✓	-	50	-	✓	✓	4	✓	1	2	1	✓	2	-	-	-	-	-	1	-	1	1	1	-	1	10	4	500K	✓	3/0	3-33	-	✓	I	64LQFP	P
LM3S2678	128	32	✓	✓	-	50	-	✓	✓	4	✓	1	4	2	✓	2	1	-	-	-	-	1	-	1	-	1	-	1	10	8	500K	✓	0/0	1-33	-	✓	I	64LQFP	P
LM3S2730	128	64	-	-	-	50	-	✓	✓	3	✓	1	-	-	-	4	-	-	-	-	-	1	-	1	-	1	-	-	-	-	-	2/0	37-60	-	✓	I/E	100LQFP 108BGA	P	
LM3S2739	128	64	-	-	-	50	-	✓	✓	3	✓	1	6	1	✓	6	1	-	-	-	-	1	-	2	1	1	-	1	10	4	500K	✓	1/0	20-56	✓	✓	I/E	100LQFP 108BGA	P
LM3S2776	128	64	✓	✓	-	50	-	✓	✓	3	✓	1	8	3	✓	1	-	-	-	-	-	1	-	1	1	1	-	1	10	6	1M	✓	0/0	0-33	✓	✓	I	64LQFP	P
LM3S2793	128	64	✓	✓	-	80	✓	✓	✓	4	✓	2	8	4	✓	8	2	✓	-	-	-	2	-	3	2	2	✓	2	10	16	1M	✓	3/16	0-67	✓	✓	I	100LQFP 108BGA	S

a. Minimum is number of pins dedicated to GPIO; additional pins are available if certain peripherals are not used. See data sheet for details.

b. Industrial (I) temperature is -40 to +85 °C and Extended (E) temperature is -40 to +105 °C.

c. USB options for Stellaris microcontrollers include Device Only (D) capability, Host/Device (H) capability, and On-The-Go/Host/Device capability (O).

d. PWM motion-control functionality can be achieved through dedicated motion control hardware (the PWM pins) or through the motion control features of the general-purpose timers (the CCP pins). See data sheet for details.

Product Selector Guide (Continued)

Part Number	Memory					Core				Timers							Serial Interfaces										Analog					5-V Tolerant GPIOs ^a	Battery-Backed Hibernation	LDO Voltage Regulator ^b	Operating Temperature ^b	Package	Production (P) or Sampling (S)		
	Flash (KB)	SRAM (KB)	ROM Software Libraries	DMA	SAFERTOS™	Max Speed (MHz)	Internal Precision Oscillator	MPU	SysTick (24-bit)	General-Purpose	Real-Time Clock (RTC)	Watchdog	Motion Control					Ethernet			CAN MAC	USB D, H, or O ^c	UART	I ² C	SSI/SPI	I ² S	ADC Units	ADC			Internal Temp Sensor							Analog/Digital Comparators	
													PWM ^d	PWM Fault	Dead-Band Generator	CCP	QEI Channels	External Peripheral Interface	10/100 MAC+PHY	10/100 MAC with MII Interface								IEEE 1588	ADC Resolution (10- or 12-bit)	ADC Channels									ADC Speed (samples per second)
LM3S2911	256	64	-	-	-	50	-	✓	✓	4	✓	1	-	-	-	8	-	-	-	-	1	-	3	2	2	-	-	-	-	-	2/0	21-60	✓	✓	I/E	100LQFP 108BGA	P		
LM3S2918	256	64	-	-	-	50	-	✓	✓	4	✓	1	-	-	-	8	-	-	-	-	1	-	2	2	2	-	1	10	8	500K	✓	2/0	15-52	✓	✓	I/E	100LQFP 108BGA	P	
LM3S2919	256	64	-	-	-	50	-	✓	✓	4	✓	1	-	-	-	8	-	-	-	1	-	2	2	2	-	1	10	8	500K	✓	2/0	15-52	✓	✓	I	100LQFP	P		
LM3S2939	256	64	-	-	-	50	-	✓	✓	3	✓	1	4	1	✓	4	1	-	-	1	-	3	1	1	-	1	10	3	500K	✓	3/0	18-57	✓	✓	I/E	100LQFP 108BGA	P		
LM3S2948	256	64	-	-	-	50	-	✓	✓	4	✓	1	-	-	-	8	-	-	-	2	-	3	1	2	-	1	10	8	1M	✓	3/0	12-52	✓	✓	I/E	100LQFP 108BGA	P		
LM3S2950	256	64	-	-	-	50	-	✓	✓	4	✓	1	6	1	✓	6	1	-	-	2	-	3	1	2	-	-	-	-	-	3/0	10-60	✓	✓	I/E	100LQFP 108BGA	P			
LM3S2965	256	64	-	-	-	50	-	✓	✓	4	✓	1	6	1	✓	6	2	-	-	2	-	3	2	2	-	1	10	4	1M	✓	3/0	3-56	✓	✓	I/E	100LQFP 108BGA	P		
LM3S2B93	256	96	✓	✓	-	80	✓	✓	✓	4	✓	2	8	4	✓	8	2	✓	-	2	-	3	2	2	✓	2	10	16	1M	✓	3/16	0-67	✓	✓	I	100LQFP 108BGA	S		
LM3S2D93	512	96	✓	✓	-	80	✓	✓	✓	4	✓	2	8	4	✓	8	2	✓	-	2	-	3	2	2	✓	2	12	16	1M	✓	3/16	0-67	✓	✓	I	100LQFP 108BGA	S		
LM3S2U93	384	96	✓	✓	-	80	✓	✓	✓	4	✓	2	8	4	✓	8	2	✓	-	2	-	3	2	2	✓	2	12	16	1M	✓	3/16	0-67	✓	✓	I	100LQFP 108BGA	S		
LM3S3634	128	32	✓	✓	-	50	-	✓	✓	3	✓	1	-	-	-	5	-	-	-	-	-	H	2	2	1	-	1	10	8	500K	✓	0/0	1-33	✓	✓	I	64LQFP	P	
LM3S3651	128	32	✓	✓	-	50	-	✓	✓	4	✓	1	-	-	-	8	-	-	-	-	-	O	1	1	1	-	1	10	4	500K	✓	2/0	0-33	✓	✓	I	64LQFP	P	
LM3S3654	128	48	✓	✓	-	50	✓	✓	✓	4	✓	2	-	-	-	8	-	-	-	-	-	O	1	1	1	-	1	10	8	500K	✓	2/8	0-33	✓	✓	I	64LQFP	S	
LM3S3739	128	64	✓	✓	-	50	-	✓	✓	4	✓	1	-	-	-	8	-	-	-	-	-	H	3	2	2	-	1	10	8	500K	✓	2/0	14-61	✓	✓	I	100LQFP	P	

a. Minimum is number of pins dedicated to GPIO; additional pins are available if certain peripherals are not used. See data sheet for details.

b. Industrial (I) temperature is -40 to +85 °C and Extended (E) temperature is -40 to +105 °C.

c. USB options for Stellaris microcontrollers include Device Only (D) capability, Host/Device (H) capability, and On-The-Go/Host/Device capability (O).

d. PWM motion-control functionality can be achieved through dedicated motion control hardware (the PWM pins) or through the motion control features of the general-purpose timers (the CCP pins). See data sheet for details.

Product Selector Guide (Continued)

Part Number	Memory					Core				Timers							Serial Interfaces										Analog					5-V Tolerant GPIOs ^a	Battery-Backed Hibernation	LDO Voltage Regulator	Operating Temperature ^b	Package	Production (P) or Sampling (S)		
	Flash (KB)	SRAM (KB)	ROM Software Libraries	DMA	SAFERTOS™	Max Speed (MHz)	Internal Precision Oscillator	MPU	SysTick (24-bit)	General-Purpose	Real-Time Clock (RTC)	Motion Control						Ethernet		CAN MAC	USB D, H, or O ^c	UART	I ² C	SSI/SPI	I ² S	ADC			Internal Temp Sensor	Analog/Digital Comparators									
												Watchdog	PWM ^d	PWM Fault	Dead-Band Generator	CCP	QEI Channels	External Peripheral Interface	10/100 MAC+PHY							10/100 MAC with MII Interface	IEEE 1588	ADC Units			ADC Resolution (10- or 12-bit)							ADC Channels	ADC Speed (samples per second)
LM3S3748	128	64	✓	✓	-	50	-	✓	✓	4	✓	1	8	4	✓	8	1	-	-	-	-	H	2	2	2	-	1	10	8	1M	✓	2/0	3-61	✓	✓	I	100LQFP	P	
LM3S3749	128	64	✓	✓	-	50	-	✓	✓	4	✓	1	8	4	✓	7	1	-	-	-	-	H	3	2	2	-	1	10	8	1M	✓	2/0	0-61	✓	✓	I	100LQFP	P	
LM3S3826	256	32	✓	✓	-	50	✓	✓	✓	3	✓	2	-	-	-	6	-	-	-	-	D	3	2	2	-	1	10	8	1M	✓	2/8	0-33	✓	✓	I	64LQFP	S		
LM3S3J26	128	20	✓	✓	-	50	✓	✓	✓	3	✓	2	-	-	-	6	-	-	-	-	D	3	2	2	-	1	10	8	1M	✓	2/8	0-33	✓	✓	I	64LQFP	S		
LM3S3N26	64	12	✓	✓	-	50	✓	✓	✓	3	✓	2	-	-	-	6	-	-	-	-	D	3	2	2	-	1	10	8	1M	✓	2/8	0-33	✓	✓	I	64LQFP	S		
LM3S3W26	32	8	✓	✓	-	50	✓	✓	✓	3	✓	2	-	-	-	6	-	-	-	-	D	3	2	2	-	1	10	8	1M	✓	2/8	0-33	✓	✓	I	64LQFP	S		
LM3S3Z26	16	6	✓	✓	-	50	✓	✓	✓	3	✓	2	-	-	-	6	-	-	-	-	D	3	2	2	-	1	10	8	1M	✓	2/8	0-33	✓	✓	I	64LQFP	S		
LM3S5632	128	32	✓	✓	-	50	-	✓	✓	3	✓	1	-	-	-	5	-	-	-	-	1	H	2	2	1	-	1	10	6	500K	✓	0/0	1-33	✓	✓	I	64LQFP	P	
LM3S5651	128	32	✓	✓	-	80	✓	✓	✓	4	✓	2	6	4	✓	8	2	-	-	-	2	O	3	2	2	✓	2	10	16	1M	✓	2/16	0-67	✓	✓	I	100LQFP 108BGA	S	
LM3S5652	128	32	✓	✓	-	50	-	✓	✓	3	✓	1	-	-	-	6	-	-	-	-	1	O	1	1	1	-	1	10	6	500K	✓	1/0	0-33	✓	✓	I	64LQFP	P	
LM3S5656	128	32	✓	✓	-	80	✓	✓	✓	4	✓	2	6	4	✓	8	1	-	-	-	1	O	3	2	2	-	2	10	8	1M	✓	2/16	0-33	✓	✓	I	64LQFP	S	
LM3S5662	128	32	✓	✓	-	50	-	✓	✓	3	✓	1	6	1	✓	5	-	-	-	-	1	O	1	-	1	-	1	10	4	500K	✓	0/0	0-33	✓	✓	I	64LQFP	P	
LM3S5732	128	64	✓	✓	-	50	-	✓	✓	3	✓	1	-	-	-	5	-	-	-	-	1	H	2	2	1	-	1	10	6	500K	✓	0/0	1-33	✓	✓	I	64LQFP	P	
LM3S5737	128	64	✓	✓	-	50	-	✓	✓	3	✓	1	-	-	-	3	-	-	-	-	1	H	1	2	2	-	1	10	8	500K	✓	0/0	27-61	✓	✓	I	100LQFP	P	
LM3S5739	128	64	✓	✓	-	50	-	✓	✓	4	✓	1	-	-	-	8	-	-	-	-	1	H	3	2	2	-	1	10	8	500K	✓	2/0	12-61	✓	✓	I	100LQFP	P	
LM3S5747	128	64	✓	✓	-	50	-	✓	✓	3	✓	1	6	1	✓	2	-	-	-	-	1	H	1	1	1	-	1	10	8	500K	✓	0/0	27-61	✓	✓	I	100LQFP	P	
LM3S5749	128	64	✓	✓	-	50	-	✓	✓	4	✓	1	8	4	✓	5	1	-	-	-	2	H	2	2	2	-	1	10	8	1M	✓	2/0	0-61	✓	✓	I	100LQFP	P	
LM3S5752	128	64	✓	✓	-	50	-	✓	✓	3	✓	1	-	-	-	6	-	-	-	-	1	O	1	1	1	-	1	10	6	500K	✓	1/0	0-33	✓	✓	I	64LQFP	P	
LM3S5762	128	64	✓	✓	-	50	-	✓	✓	3	✓	1	6	1	✓	5	-	-	-	-	1	O	1	-	1	-	1	10	4	500K	✓	0/0	0-33	✓	✓	I	64LQFP	P	

a. Minimum is number of pins dedicated to GPIO; additional pins are available if certain peripherals are not used. See data sheet for details.
 b. Industrial (I) temperature is -40 to +85 °C and Extended (E) temperature is -40 to +105 °C.
 c. USB options for Stellaris microcontrollers include Device Only (D) capability, Host/Device (H) capability, and On-The-Go/Host/Device capability (O).
 d. PWM motion-control functionality can be achieved through dedicated motion control hardware (the PWM pins) or through the motion control features of the general-purpose timers (the CCP pins). See data sheet for details.

Product Selector Guide (Continued)

Part Number	Memory					Core				Timers							Serial Interfaces										Analog					5-V Tolerant GPIOs ^a	Battery-Backed Hibernation	LDO Voltage Regulator	Operating Temperature ^b	Package	Production (P) or Sampling (S)		
	Flash (KB)	SRAM (KB)	ROM Software Libraries	DMA	SAFERTOS™	Max Speed (MHz)	Internal Precision Oscillator	MPU	SysTick (24-bit)	General-Purpose	Real-Time Clock (RTC)	Watchdog	Motion Control				Ethernet		CAN MAC	USB D, H, or O ^c	UART	I ² C	SSI/SPI	I ² S	ADC Units	ADC			Internal Temp Sensor	Analog/Digital Comparators									
													PWM ^d	PWM Fault	Dead-Band Generator	CCP	QEI Channels	External Peripheral Interface								10/100 MAC+PHY	10/100 MAC with MII Interface	IEEE 1588			ADC Resolution (10- or 12-bit)							ADC Channels	ADC Speed (samples per second)
LM3S5791	128	64	✓	✓	-	80	✓	✓	✓	4	✓	2	8	4	✓	8	2	✓	-	-	-	2	O	3	2	2	✓	2	10	16	1M	✓	3/16	0-72	-	✓	I	100LQFP 108BGA	S
LM3S5951	256	64	✓	✓	-	80	✓	✓	✓	4	✓	2	6	4	✓	8	2	-	-	-	-	2	O	3	2	2	✓	2	10	16	1M	✓	2/16	0-67	✓	✓	I	100LQFP 108BGA	S
LM3S5956	256	64	✓	✓	-	80	✓	✓	✓	4	✓	2	6	4	✓	8	1	-	-	-	-	1	O	3	2	2	-	2	10	8	1M	✓	2/16	0-33	✓	✓	I	64LQFP	S
LM3S5B91	256	96	✓	✓	-	80	✓	✓	✓	4	✓	2	8	4	✓	8	2	✓	-	-	-	2	O	3	2	2	✓	2	10	16	1M	✓	3/16	0-72	-	✓	I	100LQFP 108BGA	S
LM3S5C31	512	64	✓	✓	-	80	✓	✓	✓	3	✓	2	6	4	✓	6	2	✓	-	-	-	1	D	3	2	2	-	2	12	16	1M	✓	2/16	0-67	✓	✓	I	100LQFP 108BGA	S
LM3S5C36	512	64	✓	✓	-	80	✓	✓	✓	4	✓	2	8	4	✓	8	1	-	-	-	-	1	D	3	2	2	-	2	12	8	1M	✓	2/16	0-33	✓	✓	I	64LQFP	S
LM3S5C51	512	64	✓	✓	-	80	✓	✓	✓	4	✓	2	6	4	✓	8	2	-	-	-	-	2	O	3	2	2	✓	2	12	16	1M	✓	2/16	0-67	✓	✓	I	100LQFP 108BGA	S
LM3S5C56	512	64	✓	✓	-	80	✓	✓	✓	4	✓	2	6	4	✓	8	1	-	-	-	-	1	O	3	2	2	-	2	12	8	1M	✓	2/16	0-33	✓	✓	I	64LQFP	S
LM3S5D51	512	96	✓	✓	-	80	✓	✓	✓	4	✓	2	6	4	✓	8	2	-	-	-	-	2	O	3	2	2	✓	2	12	16	1M	✓	2/16	0-67	✓	✓	I	100LQFP 108BGA	S
LM3S5D56	512	96	✓	✓	-	80	✓	✓	✓	4	✓	2	6	4	✓	8	1	-	-	-	-	1	O	3	2	2	-	2	12	8	1M	✓	2/16	0-33	✓	✓	I	64LQFP	S
LM3S5D91	512	96	✓	✓	-	80	✓	✓	✓	4	✓	2	8	4	✓	8	2	✓	-	-	-	2	O	3	2	2	✓	2	12	16	1M	✓	3/16	0-72	-	✓	I	100LQFP 108BGA	S
LM3S5G31	384	64	✓	✓	-	80	✓	✓	✓	3	✓	2	6	4	✓	6	2	✓	-	-	-	1	D	3	2	2	-	2	12	16	1M	✓	2/16	0-67	✓	✓	I	100LQFP 108BGA	S
LM3S5G36	384	64	✓	✓	-	80	✓	✓	✓	4	✓	2	8	4	✓	8	1	-	-	-	-	1	D	3	2	2	-	2	12	8	1M	✓	2/16	0-33	✓	✓	I	64LQFP	S
LM3S5G51	384	64	✓	✓	-	80	✓	✓	✓	4	✓	2	6	4	✓	8	2	-	-	-	-	2	O	3	2	2	✓	2	12	16	1M	✓	2/16	0-67	✓	✓	I	100LQFP 108BGA	S

a. Minimum is number of pins dedicated to GPIO; additional pins are available if certain peripherals are not used. See data sheet for details.
 b. Industrial (I) temperature is -40 to +85 °C and Extended (E) temperature is -40 to +105 °C.
 c. USB options for Stellaris microcontrollers include Device Only (D) capability, Host/Device (H) capability, and On-The-Go/Host/Device capability (O).
 d. PWM motion-control functionality can be achieved through dedicated motion control hardware (the PWM pins) or through the motion control features of the general-purpose timers (the CCP pins). See data sheet for details.

Product Selector Guide (Continued)

Part Number	Memory					Core				Timers							Serial Interfaces										Analog					5-V Tolerant GPIOs ^a	Battery-Backed Hibernation	LDO Voltage Regulator	Operating Temperature ^b	Package	Production (P) or Sampling (S)		
	Flash (KB)	SRAM (KB)	ROM Software Libraries	DMA	SAFERTOS™	Max Speed (MHz)	Internal Precision Oscillator	MPU	SysTick (24-bit)	General-Purpose	Real-Time Clock (RTC)	Watchdog	Motion Control					Ethernet					ADC																
													PWM ^d	PWM Fault	Dead-Band Generator	CCP	QEI Channels	External Peripheral Interface	10/100 MAC+PHY	10/100 MAC with MII Interface	IEEE 1588	CAN MAC	USB D, H, or O ^c	UART	I ² C	SSI/SPI	I ² S	ADC Units	ADC Resolution (10- or 12-bit)	ADC Channels	ADC Speed (samples per second)							Internal Temp Sensor	Analog/Digital Comparators
LM3S5G56	384	64	✓	✓	-	80	✓	✓	✓	4	✓	2	6	4	✓	6	2	-	-	-	-	1	O	3	2	2	-	2	12	8	1M	✓	2/16	0-33	✓	✓	I	64LQFP	S
LM3S5K31	128	24	✓	✓	-	80	✓	✓	✓	3	✓	2	6	4	✓	6	2	-	-	-	-	1	D	3	2	2	-	2	10	16	1M	✓	2/16	0-67	✓	✓	I	100LQFP 108BGA	S
LM3S5K36	128	24	✓	✓	-	80	✓	✓	✓	3	✓	2	6	4	✓	6	1	-	-	-	-	1	D	3	2	2	-	2	10	8	1M	✓	2/16	0-33	✓	✓	I	64LQFP	S
LM3S5P31	64	24	✓	✓	-	80	✓	✓	✓	3	✓	2	6	4	✓	6	2	-	-	-	-	1	D	3	2	2	-	2	10	16	1M	✓	2/16	0-67	✓	✓	I	100LQFP 108BGA	S
LM3S5P36	64	24	✓	✓	-	80	✓	✓	✓	3	✓	2	6	4	✓	6	1	-	-	-	-	1	D	3	2	2	-	2	10	8	1M	✓	2/16	0-33	✓	✓	I	64LQFP	S
LM3S5P3B	64	24	✓	✓	-	80	✓	✓	✓	3	✓	2	6	4	✓	6	2	-	-	-	-	1	D	3	2	2	✓	2	10	16	1M	✓	2/16	0-67	✓	✓	I	100LQFP 108BGA	S
LM3S5P51	64	24	✓	✓	-	80	✓	✓	✓	4	✓	2	6	4	✓	8	2	-	-	-	-	2	O	3	2	2	✓	2	10	16	1M	✓	2/16	0-67	✓	✓	I	100LQFP 108BGA	S
LM3S5P56	64	24	✓	✓	-	80	✓	✓	✓	4	✓	2	6	4	✓	8	1	-	-	-	-	1	O	3	2	2	-	2	10	8	1M	✓	2/16	0-33	✓	✓	I	64LQFP	S
LM3S5R31	256	48	✓	✓	-	80	✓	✓	✓	4	✓	2	8	4	✓	8	2	✓	-	-	-	1	D	3	2	2	✓	2	10	16	1M	✓	2/16	0-67	✓	✓	I	100LQFP 108BGA	S
LM3S5R36	256	48	✓	✓	-	80	✓	✓	✓	4	✓	2	8	4	✓	8	1	-	-	-	-	1	D	3	2	2	-	2	10	8	1M	✓	2/16	0-33	✓	✓	I	64LQFP	S
LM3S5T36	32	12	✓	✓	-	80	✓	✓	✓	3	✓	2	6	4	✓	6	1	-	-	-	-	1	D	3	2	2	-	2	10	8	1M	✓	2/16	0-33	✓	✓	I	64LQFP	S
LM3S5U91	384	96	✓	✓	-	80	✓	✓	✓	4	✓	2	8	4	✓	8	2	✓	-	-	-	2	O	3	2	2	✓	2	12	16	1M	✓	3/16	0-72	-	✓	I	100LQFP 108BGA	S
LM3S5Y36	16	8	✓	✓	-	80	✓	✓	✓	3	✓	2	6	4	✓	6	1	-	-	-	-	1	D	3	2	2	-	2	10	8	1M	✓	2/16	0-33	✓	✓	I	64LQFP	S
LM3S6100	64	16	-	-	-	25	-	✓	✓	3	✓	1	-	-	-	4	-	-	✓	-	-	-	-	1	-	1	-	-	-	-	-	-	1/0	10-30	-	✓	I/E	100LQFP 108BGA	P
LM3S6110	64	16	-	-	-	25	-	✓	✓	3	✓	1	2	1	✓	4	-	-	✓	-	-	-	-	1	-	1	-	-	-	-	-	-	3/0	8-35	-	✓	I/E	100LQFP 108BGA	P

a. Minimum is number of pins dedicated to GPIO; additional pins are available if certain peripherals are not used. See data sheet for details.

b. Industrial (I) temperature is -40 to +85 °C and Extended (E) temperature is -40 to +105 °C.

c. USB options for Stellaris microcontrollers include Device Only (D) capability, Host/Device (H) capability, and On-The-Go/Host/Device capability (O).

d. PWM motion-control functionality can be achieved through dedicated motion control hardware (the PWM pins) or through the motion control features of the general-purpose timers (the CCP pins). See data sheet for details.

Product Selector Guide (Continued)

Part Number	Memory					Core				Timers							Serial Interfaces										Analog					5-V Tolerant GPIOs ^a	Battery-Backed Hibernation	LDO Voltage Regulator	Operating Temperature ^b	Package	Production (P) or Sampling (S)		
	Flash (KB)	SRAM (KB)	ROM Software Libraries	DMA	SAFERTOS™	Max Speed (MHz)	Internal Precision Oscillator	MPU	SysTick (24-bit)	General-Purpose	Real-Time Clock (RTC)	Watchdog	Motion Control					Ethernet		CAN MAC	USB D, H, or O ^c	UART	I ² C	SSI/SPI	I ² S	ADC Units	ADC			Internal Temp Sensor	Analog/Digital Comparators								
													PWM ^d	PWM Fault	Dead-Band Generator	CCP	QEI Channels	External Peripheral Interface	10/100 MAC+PHY								10/100 MAC with MII Interface	IEEE 1588	ADC Resolution (10- or 12-bit)									ADC Channels	ADC Speed (samples per second)
LM3S6420	96	32	-	-	-	25	-	✓	✓	3	✓	1	-	-	-	4	-	-	✓	-	-	-	1	-	1	-	-	-	-	2/0	23-46	-	✓	I/E	100LQFP 108BGA	P			
LM3S6422	96	32	-	-	-	25	-	✓	✓	3	✓	1	-	-	-	4	-	-	✓	-	-	-	1	-	1	-	1	10	2	250K	✓	2/0	12-34	-	✓	I/E	100LQFP 108BGA	P	
LM3S6432	96	32	-	-	-	50	-	✓	✓	3	✓	1	2	1	✓	4	-	-	✓	-	-	-	2	1	1	-	1	10	3	250K	✓	2/0	14-43	-	✓	I/E	100LQFP 108BGA	P	
LM3S6537	96	64	-	-	-	50	-	✓	✓	4	✓	1	6	1	✓	6	-	-	✓	-	✓	-	2	1	1	-	1	10	4	500K	✓	2/0	6-41	✓	✓	I/E	100LQFP 108BGA	P	
LM3S6610	128	32	-	-	-	25	-	✓	✓	4	✓	1	4	1	✓	6	1	-	✓	-	-	-	3	1	1	-	-	-	-	-	3/0	5-46	✓	✓	I/E	100LQFP 108BGA	P		
LM3S6611	128	32	-	-	-	50	-	✓	✓	4	✓	1	-	-	-	6	-	-	✓	-	-	-	3	2	2	-	-	-	-	-	2/0	10-46	✓	✓	I/E	100LQFP 108BGA	P		
LM3S6618	128	32	-	-	-	50	-	✓	✓	4	✓	1	-	-	-	6	-	-	✓	-	-	-	2	2	2	-	1	10	8	500K	✓	2/0	5-38	✓	✓	I/E	100LQFP 108BGA	P	
LM3S6633	128	32	-	-	-	50	-	✓	✓	3	✓	1	-	-	-	6	-	-	✓	-	-	-	2	1	1	-	1	10	3	500K	✓	1/0	15-41	✓	✓	I/E	100LQFP 108BGA	P	
LM3S6637	128	32	-	-	-	50	-	✓	✓	4	✓	1	-	-	-	6	-	-	✓	-	-	-	2	1	1	-	1	10	4	1M	✓	3/0	11-41	✓	✓	I/E	100LQFP 108BGA	P	
LM3S6730	128	64	-	-	-	50	-	✓	✓	3	✓	1	-	-	-	4	-	-	✓	-	-	-	1	-	1	-	-	-	-	-	2/0	23-46	-	✓	I/E	100LQFP 108BGA	P		
LM3S6753	128	64	-	-	-	50	-	✓	✓	4	✓	1	6	1	✓	4	1	-	✓	-	✓	-	2	1	1	-	1	10	4	500K	✓	2/0	5-41	✓	✓	I/E	100LQFP 108BGA	P	
LM3S6911	256	64	-	-	-	50	-	✓	✓	4	✓	1	-	-	-	6	-	-	✓	-	-	-	3	2	2	-	-	-	-	-	2/0	10-46	✓	✓	I/E	100LQFP 108BGA	P		

a. Minimum is number of pins dedicated to GPIO; additional pins are available if certain peripherals are not used. See data sheet for details.
 b. Industrial (I) temperature is -40 to +85 °C and Extended (E) temperature is -40 to +105 °C.
 c. USB options for Stellaris microcontrollers include Device Only (D) capability, Host/Device (H) capability, and On-The-Go/Host/Device capability (O).
 d. PWM motion-control functionality can be achieved through dedicated motion control hardware (the PWM pins) or through the motion control features of the general-purpose timers (the CCP pins). See data sheet for details.

Product Selector Guide (Continued)

Part Number	Memory					Core				Timers							Serial Interfaces										Analog					5-V Tolerant GPIOs ^a	Battery-Backed Hibernation	LDO Voltage Regulator	Operating Temperature ^b	Package	Production (P) or Sampling (S)		
	Flash (KB)	SRAM (KB)	ROM Software Libraries	DMA	SAFERTOS™	Max Speed (MHz)	Internal Precision Oscillator	MPU	SysTick (24-bit)	General-Purpose	Real-Time Clock (RTC)	Watchdog	Motion Control					Ethernet			CAN MAC	USB D, H, or O ^c	UART	I ² C	SSI/SPI	I ² S	ADC			Internal Temp Sensor	Analog/Digital Comparators								
													PWM ^d	PWM Fault	Dead-Band Generator	CCP	QEI Channels	External Peripheral Interface	10/100 MAC+PHY	10/100 MAC with MII Interface							IEEE 1588	ADC Units	ADC Resolution (10- or 12-bit)									ADC Channels	ADC Speed (samples per second)
LM3S6918	256	64	-	-	-	50	-	✓	✓	4	✓	1	-	-	-	6	-	-	✓	-	-	-	2	2	2	-	1	10	8	500K	✓	2/0	5-38	✓	✓	I/E	100LQFP 108BGA	P	
LM3S6938	256	64	-	-	-	50	-	✓	✓	4	✓	1	-	-	-	6	-	-	✓	-	-	-	3	1	1	-	1	10	8	1M	✓	3/0	7-38	✓	✓	I/E	100LQFP 108BGA	P	
LM3S6950	256	64	-	-	-	50	-	✓	✓	4	✓	1	6	1	✓	6	1	-	✓	-	✓	-	3	1	2	-	-	-	-	-	3/0	1-46	✓	✓	I/E	100LQFP 108BGA	P		
LM3S6952	256	64	-	-	-	50	-	✓	✓	3	✓	1	4	1	✓	4	1	-	✓	-	-	-	3	1	1	-	1	10	3	500K	✓	3/0	6-43	✓	✓	I/E	100LQFP 108BGA	P	
LM3S6965	256	64	-	-	-	50	-	✓	✓	4	✓	1	6	1	✓	4	2	-	✓	-	-	-	3	2	1	-	1	10	4	1M	✓	2/0	0-42	✓	✓	I/E	100LQFP 108BGA	P	
LM3S6C11	512	64	✓	✓	-	80	✓	✓	✓	4	✓	2	-	-	-	8	-	-	✓	-	-	-	3	2	2	-	-	-	-	-	2/0	0-46	✓	✓	I	100LQFP 108BGA	S		
LM3S6C65	512	64	✓	✓	-	80	✓	✓	✓	4	✓	2	6	4	✓	8	2	-	✓	-	-	-	3	2	1	-	2	12	16	1M	✓	2/16	0-46	✓	✓	I	100LQFP 108BGA	S	
LM3S6G11	384	64	✓	✓	-	80	✓	✓	✓	4	✓	2	-	-	-	8	-	-	✓	-	-	-	3	2	2	-	-	-	-	-	2/0	0-46	✓	✓	I	100LQFP 108BGA	S		
LM3S6G65	384	64	✓	✓	-	80	✓	✓	✓	4	✓	2	6	4	✓	8	2	-	✓	-	-	-	3	2	1	-	2	12	16	1M	✓	2/16	0-46	✓	✓	I	100LQFP 108BGA	S	
LM3S8530	96	64	-	-	-	50	-	✓	✓	4	✓	1	-	-	-	2	-	-	✓	-	-	3	-	1	1	2	-	-	-	-	0/0	8-35	-	✓	I/E	100LQFP 108BGA	P		
LM3S8538	96	64	-	-	-	50	-	✓	✓	4	✓	1	-	-	-	4	-	-	✓	-	✓	1	-	2	1	1	-	1	10	8	1M	✓	3/0	7-36	-	✓	I/E	100LQFP 108BGA	P
LM3S8630	128	32	-	-	-	50	-	✓	✓	4	✓	1	-	-	-	2	-	-	✓	-	-	1	-	2	1	1	-	-	-	-	0/0	10-31	✓	✓	I/E	100LQFP 108BGA	P		

a. Minimum is number of pins dedicated to GPIO; additional pins are available if certain peripherals are not used. See data sheet for details.
 b. Industrial (I) temperature is -40 to +85 °C and Extended (E) temperature is -40 to +105 °C.
 c. USB options for Stellaris microcontrollers include Device Only (D) capability, Host/Device (H) capability, and On-The-Go/Host/Device capability (O).
 d. PWM motion-control functionality can be achieved through dedicated motion control hardware (the PWM pins) or through the motion control features of the general-purpose timers (the CCP pins). See data sheet for details.

Product Selector Guide (Continued)

Part Number	Memory					Core				Timers							Serial Interfaces										Analog					5-V Tolerant GPIOs ^a	Battery-Backed Hibernation	LDO Voltage Regulator	Operating Temperature ^b	Package	Production (P) or Sampling (S)		
	Flash (KB)	SRAM (KB)	ROM Software Libraries	DMA	SAFERTOS™	Max Speed (MHz)	Internal Precision Oscillator	MPU	SysTick (24-bit)	General-Purpose	Real-Time Clock (RTC)	Watchdog	Motion Control					Ethernet			CAN MAC	USB D, H, or O ^c	UART	I ² C	SSI/SPI	I ² S	ADC Units	ADC			Internal Temp Sensor							Analog/Digital Comparators	
													PWM ^d	PWM Fault	Dead-Band Generator	CCP	QEI Channels	External Peripheral Interface	10/100 MAC+PHY	10/100 MAC with MII Interface								IEEE 1588	ADC Resolution (10- or 12-bit)	ADC Channels									ADC Speed (samples per second)
LM3S8730	128	64	-	-	-	50	-	✓	✓	4	✓	1	-	-	-	2	-	-	✓	-	✓	1	-	2	1	1	-	-	-	-	0/0	11-32	✓	✓	I/E	100LQFP 108BGA	P		
LM3S8733	128	64	-	-	-	50	-	✓	✓	4	✓	1	-	-	-	4	-	-	✓	-	-	1	-	2	1	1	-	1	10	4	500K	✓	3/0	5-35	✓	✓	I/E	100LQFP 108BGA	P
LM3S8738	128	64	-	-	-	50	-	✓	✓	4	✓	1	-	-	-	6	-	-	✓	-	-	1	-	3	1	2	-	1	10	8	500K	✓	1/0	4-38	✓	✓	I/E	100LQFP 108BGA	P
LM3S8930	256	64	-	-	-	50	-	✓	✓	4	✓	1	-	-	-	2	-	-	✓	-	-	2	-	1	1	1	-	-	-	-	0/0	13-34	✓	✓	I/E	100LQFP 108BGA	P		
LM3S8933	256	64	-	-	-	50	-	✓	✓	4	✓	1	-	-	-	4	-	-	✓	-	✓	1	-	2	1	1	-	1	10	4	1M	✓	3/0	6-36	✓	✓	I/E	100LQFP 108BGA	P
LM3S8938	256	64	-	-	-	50	-	✓	✓	4	✓	1	-	-	-	6	-	-	✓	-	✓	1	-	3	2	1	-	1	10	8	1M	✓	3/0	3-38	✓	✓	I/E	100LQFP 108BGA	P
LM3S8962	256	64	-	-	-	50	-	✓	✓	4	✓	1	6	1	✓	2	2	-	✓	-	✓	1	-	2	1	1	-	1	10	4	500K	✓	1/0	5-42	✓	✓	I/E	100LQFP 108BGA	P
LM3S8970	256	64	-	-	-	50	-	✓	✓	4	✓	1	-	-	-	2	-	-	✓	-	✓	3	-	2	1	2	-	-	-	-	0/0	17-46	✓	✓	I/E	100LQFP 108BGA	P		
LM3S8971	256	64	-	-	-	50	-	✓	✓	4	✓	1	6	1	✓	6	1	-	✓	-	-	1	-	1	-	1	-	1	10	8	1M	✓	1/0	4-38	✓	✓	I/E	100LQFP 108BGA	P
LM3S8C62	512	64	✓	✓	-	80	✓	✓	✓	4	✓	2	6	4	✓	8	2	-	✓	-	-	1	-	2	1	1	-	2	12	16	1M	✓	2/16	0-46	✓	✓	I	100LQFP 108BGA	S
LM3S8G62	384	64	✓	✓	-	80	✓	✓	✓	4	✓	2	6	4	✓	8	2	-	✓	-	-	1	-	2	1	1	-	2	12	16	1M	✓	2/16	0-46	✓	✓	I	100LQFP 108BGA	S
LM3S9781	128	64	✓	✓	-	80	✓	✓	✓	4	✓	2	-	-	-	8	-	✓	✓	-	-	3	O	3	2	2	✓	2	10	16	1M	✓	3/16	0-65	-	✓	I	100LQFP 108BGA	S

a. Minimum is number of pins dedicated to GPIO; additional pins are available if certain peripherals are not used. See data sheet for details.
 b. Industrial (I) temperature is -40 to +85 °C and Extended (E) temperature is -40 to +105 °C.
 c. USB options for Stellaris microcontrollers include Device Only (D) capability, Host/Device (H) capability, and On-The-Go/Host/Device capability (O).
 d. PWM motion-control functionality can be achieved through dedicated motion control hardware (the PWM pins) or through the motion control features of the general-purpose timers (the CCP pins). See data sheet for details.

Product Selector Guide (Continued)

Part Number	Memory					Core				Timers							Serial Interfaces										Analog					5-V Tolerant GPIOs ^a	Battery-Backed Hibernation	LDO Voltage Regulator	Operating Temperature ^b	Package	Production (P) or Sampling (S)		
	Flash (KB)	SRAM (KB)	ROM Software Libraries	DMA	SAFERTOS™	Max Speed (MHz)	Internal Precision Oscillator	MPU	SysTick (24-bit)	General-Purpose	Real-Time Clock (RTC)	Watchdog	Motion Control					Ethernet					ADC																
													PWM ^d	PWM Fault	Dead-Band Generator	CCP	QEI Channels	External Peripheral Interface	10/100 MAC+PHY	10/100 MAC with MII Interface	IEEE 1588	CAN MAC	USB D, H, or O ^c	UART	I ² C	SSI/SPI	I ² S	ADC Units	ADC Resolution (10- or 12-bit)	ADC Channels	ADC Speed (samples per second)							Internal Temp Sensor	Analog/Digital Comparators
LM3S9790	128	64	✓	✓	-	80	✓	✓	✓	4	✓	2	-	-	-	8	-	✓	✓	✓	✓	✓	✓	2	10	16	1M	✓	3/16	0-60	✓	✓	I	100LQFP 108BGA	S				
LM3S9792	128	64	✓	✓	-	80	✓	✓	✓	4	✓	2	8	4	✓	8	2	✓	✓	-	-	2	O	3	2	2	✓	2	10	16	1M	✓	3/16	0-65	-	✓	I	100LQFP 108BGA	S
LM3S9971	256	64	✓	✓	-	80	✓	✓	✓	4	✓	2	6	4	✓	8	2	-	-	✓	✓	2	O	3	2	2	✓	2	10	16	1M	✓	2/16	0-72	-	✓	I	100LQFP 108BGA	S
LM3S9997	256	64	✓	✓	-	80	✓	✓	✓	4	✓	2	6	4	✓	8	2	-	-	✓	✓	2	O	3	2	2	✓	2	10	16	1M	✓	2/16	0-60	✓	✓	I	100LQFP 108BGA	S
LM3S9B81	256	96	✓	✓	-	80	✓	✓	✓	4	✓	2	-	-	-	8	-	✓	✓	-	-	3	O	3	2	2	✓	2	10	16	1M	✓	3/16	0-65	-	✓	I	100LQFP 108BGA	S
LM3S9B90	256	96	✓	✓	-	80	✓	✓	✓	4	✓	2	-	-	-	8	-	✓	✓	-	-	2	O	3	2	2	✓	2	10	16	1M	✓	3/16	0-60	✓	✓	I	100LQFP 108BGA	S
LM3S9B92	256	96	✓	✓	-	80	✓	✓	✓	4	✓	2	8	4	✓	8	2	✓	✓	-	-	2	O	3	2	2	✓	2	10	16	1M	✓	3/16	0-65	-	✓	I	100LQFP 108BGA	S
LM3S9B95	256	96	✓	✓	-	80	✓	✓	✓	4	✓	2	8	4	✓	8	2	✓	✓	-	✓	2	O	3	2	2	✓	2	10	16	1M	✓	3/16	0-65	-	✓	I	100LQFP 108BGA	S
LM3S9B96	256	96	✓	✓	✓	80	✓	✓	✓	4	✓	2	8	4	✓	8	2	✓	✓	-	✓	2	O	3	2	2	✓	2	10	16	1M	✓	3/16	0-65	-	✓	I	100LQFP 108BGA	S
LM3S9BN2	256	96	✓	✓	-	80	✓	✓	✓	4	✓	2	8	4	✓	8	2	✓	-	✓	-	2	O	3	2	2	✓	2	10	16	1M	✓	3/16	0-72	-	✓	I	100LQFP 108BGA	S
LM3S9BN5	256	96	✓	✓	-	80	✓	✓	✓	4	✓	2	8	4	✓	8	2	✓	-	✓	✓	2	O	3	2	2	✓	2	10	16	1M	✓	3/16	0-72	-	✓	I	100LQFP 108BGA	S
LM3S9BN6	256	96	✓	✓	✓	80	✓	✓	✓	4	✓	2	8	4	✓	8	2	✓	-	✓	✓	2	O	3	2	2	✓	2	10	16	1M	✓	3/16	0-72	-	✓	I	100LQFP 108BGA	S

a. Minimum is number of pins dedicated to GPIO; additional pins are available if certain peripherals are not used. See data sheet for details.

b. Industrial (I) temperature is -40 to +85 °C and Extended (E) temperature is -40 to +105 °C.

c. USB options for Stellaris microcontrollers include Device Only (D) capability, Host/Device (H) capability, and On-The-Go/Host/Device capability (O).

d. PWM motion-control functionality can be achieved through dedicated motion control hardware (the PWM pins) or through the motion control features of the general-purpose timers (the CCP pins). See data sheet for details.

Product Selector Guide (Continued)

Part Number	Memory					Core				Timers							Serial Interfaces										Analog					5-V Tolerant GPIOs ^a	Battery-Backed Hibernation	LDO Voltage Regulator	Operating Temperature ^b	Package	Production (P) or Sampling (S)		
	Flash (KB)	SRAM (KB)	ROM Software Libraries	DMA	SAFERTOS™	Max Speed (MHz)	Internal Precision Oscillator	MPU	SysTick (24-bit)	General-Purpose	Real-Time Clock (RTC)	Watchdog	Motion Control					Ethernet					ADC																
													PWM ^d	PWM Fault	Dead-Band Generator	CCP	QEI Channels	External Peripheral Interface	10/100 MAC+PHY	10/100 MAC with MII Interface	IEEE 1588	CAN MAC	USB D, H, or O ^c	UART	I ² C	SSI/SPI	I ² S	ADC Units	ADC Resolution (10- or 12-bit)	ADC Channels	ADC Speed (samples per second)							Internal Temp Sensor	Analog/Digital Comparators
LM3S9C97	512	64	✓	✓	-	80	✓	✓	✓	4	✓	2	6	4	✓	8	2	-	✓	-	✓	2	O	3	2	2	✓	2	12	16	1M	✓	2/16	0-60	✓	✓	I	100LQFP 108BGA	S
LM3S9CN5	512	64	✓	✓	-	80	✓	✓	✓	4	✓	2	8	4	✓	8	2	✓	-	✓	✓	2	O	3	2	2	✓	2	12	16	1M	✓	3/16	0-72	-	✓	I	100LQFP 108BGA	S
LM3S9D81	512	96	✓	✓	-	80	✓	✓	✓	4	✓	2	-	-	-	8	-	✓	✓	-	-	3	O	3	2	2	✓	2	12	16	1M	✓	3/16	0-65	-	✓	I	100LQFP 108BGA	S
LM3S9D90	512	96	✓	✓	-	80	✓	✓	✓	4	✓	2	-	-	-	8	-	✓	✓	-	-	2	O	3	2	2	✓	2	12	16	1M	✓	3/16	0-60	✓	✓	I	100LQFP 108BGA	S
LM3S9D92	512	96	✓	✓	-	80	✓	✓	✓	4	✓	2	8	4	✓	8	2	✓	✓	-	✓	2	O	3	2	2	✓	2	12	16	1M	✓	3/16	0-65	-	✓	I	100LQFP 108BGA	S
LM3S9D95	512	96	✓	✓	-	80	✓	✓	✓	4	✓	2	8	4	✓	8	2	✓	✓	-	✓	2	O	3	2	2	✓	2	12	16	1M	✓	3/16	0-65	-	✓	I	100LQFP 108BGA	S
LM3S9D96	512	96	✓	✓	✓	80	✓	✓	✓	4	✓	2	8	4	✓	8	2	✓	✓	-	✓	2	O	3	2	2	✓	2	12	16	1M	✓	3/16	0-65	-	✓	I	100LQFP 108BGA	S
LM3S9DN5	512	96	✓	✓	-	80	✓	✓	✓	4	✓	2	8	4	✓	8	2	✓	-	✓	✓	2	O	3	2	2	✓	2	12	16	1M	✓	3/16	0-72	-	✓	I	100LQFP 108BGA	S
LM3S9DN6	512	96	✓	✓	✓	80	✓	✓	✓	4	✓	2	8	4	✓	8	2	✓	-	✓	✓	2	O	3	2	2	✓	2	12	16	1M	✓	3/16	0-72	-	✓	I	100LQFP 108BGA	S
LM3S9G97	384	64	✓	✓	-	80	✓	✓	✓	4	✓	2	6	4	✓	8	2	-	✓	-	✓	2	O	3	2	2	✓	2	12	16	1M	✓	2/16	0-60	✓	✓	I	100LQFP 108BGA	S
LM3S9GN5	384	64	✓	✓	-	80	✓	✓	✓	4	✓	2	8	4	✓	8	2	✓	-	✓	✓	2	O	3	2	2	✓	2	12	16	1M	✓	3/16	0-72	-	✓	I	100LQFP 108BGA	S
LM3S9L71	128	48	✓	✓	-	80	✓	✓	✓	4	✓	2	6	4	✓	8	2	-	-	✓	✓	2	O	3	2	2	✓	2	10	16	1M	✓	2/16	0-72	-	✓	I	100LQFP 108BGA	S

a. Minimum is number of pins dedicated to GPIO; additional pins are available if certain peripherals are not used. See data sheet for details.

b. Industrial (I) temperature is -40 to +85 °C and Extended (E) temperature is -40 to +105 °C.

c. USB options for Stellaris microcontrollers include Device Only (D) capability, Host/Device (H) capability, and On-The-Go/Host/Device capability (O).

d. PWM motion-control functionality can be achieved through dedicated motion control hardware (the PWM pins) or through the motion control features of the general-purpose timers (the CCP pins). See data sheet for details.

Product Selector Guide (Continued)

Part Number	Memory					Core				Timers							Serial Interfaces										Analog					5-V Tolerant GPIOs ^a	Battery-Backed Hibernation	LDO Voltage Regulator	Operating Temperature ^b	Package	Production (P) or Sampling (S)		
	Flash (KB)	SRAM (KB)	ROM Software Libraries	DMA	SAFERTOS™	Max Speed (MHz)	Internal Precision Oscillator	MPU	SysTick (24-bit)	General-Purpose	Real-Time Clock (RTC)	Watchdog	Motion Control					Ethernet					ADC																
													PWM ^d	PWM Fault	Dead-Band Generator	CCP	QEI Channels	External Peripheral Interface	10/100 MAC+PHY	10/100 MAC with MII Interface	IEEE 1588	CAN MAC	USB D, H, or O ^c	UART	I ² C	SSI/SPI	I ² S	ADC Units	ADC Resolution (10- or 12-bit)	ADC Channels	ADC Speed (samples per second)							Internal Temp Sensor	Analog/Digital Comparators
LM3S9L97	128	48	✓	✓	-	80	✓	✓	✓	4	✓	2	6	4	✓	8	2	-	✓	-	✓	2	O	3	2	2	✓	2	10	16	1M	✓	2/16	0-60	✓	✓	I	100LQFP 108BGA	S
LM3S9U81	384	96	✓	✓	-	80	✓	✓	✓	4	✓	2	-	-	-	8	-	✓	✓	-	-	3	O	3	2	2	✓	2	12	16	1M	✓	3/16	0-65	-	✓	I	100LQFP 108BGA	S
LM3S9U90	384	96	✓	✓	-	80	✓	✓	✓	4	✓	2	-	-	-	8	-	✓	✓	-	-	2	O	3	2	2	✓	2	12	16	1M	✓	3/16	0-60	✓	✓	I	100LQFP 108BGA	S
LM3S9U92	384	96	✓	✓	-	80	✓	✓	✓	4	✓	2	8	4	✓	8	2	✓	✓	-	✓	2	O	3	2	2	✓	2	12	16	1M	✓	3/16	0-65	-	✓	I	100LQFP 108BGA	S
LM3S9U95	384	96	✓	✓	-	80	✓	✓	✓	4	✓	2	8	4	✓	8	2	✓	✓	-	✓	2	O	3	2	2	✓	2	12	16	1M	✓	3/16	0-65	-	✓	I	100LQFP 108BGA	S
LM3S9U96	384	96	✓	✓	✓	80	✓	✓	✓	4	✓	2	8	4	✓	8	2	✓	✓	-	✓	2	O	3	2	2	✓	2	12	16	1M	✓	3/16	0-65	-	✓	I	100LQFP 108BGA	S

a. Minimum is number of pins dedicated to GPIO; additional pins are available if certain peripherals are not used. See data sheet for details.

b. Industrial (I) temperature is -40 to +85 °C and Extended (E) temperature is -40 to +105 °C.

c. USB options for Stellaris microcontrollers include Device Only (D) capability, Host/Device (H) capability, and On-The-Go/Host/Device capability (O).

d. PWM motion-control functionality can be achieved through dedicated motion control hardware (the PWM pins) or through the motion control features of the general-purpose timers (the CCP pins). See data sheet for details.

Full Part Number Decoder

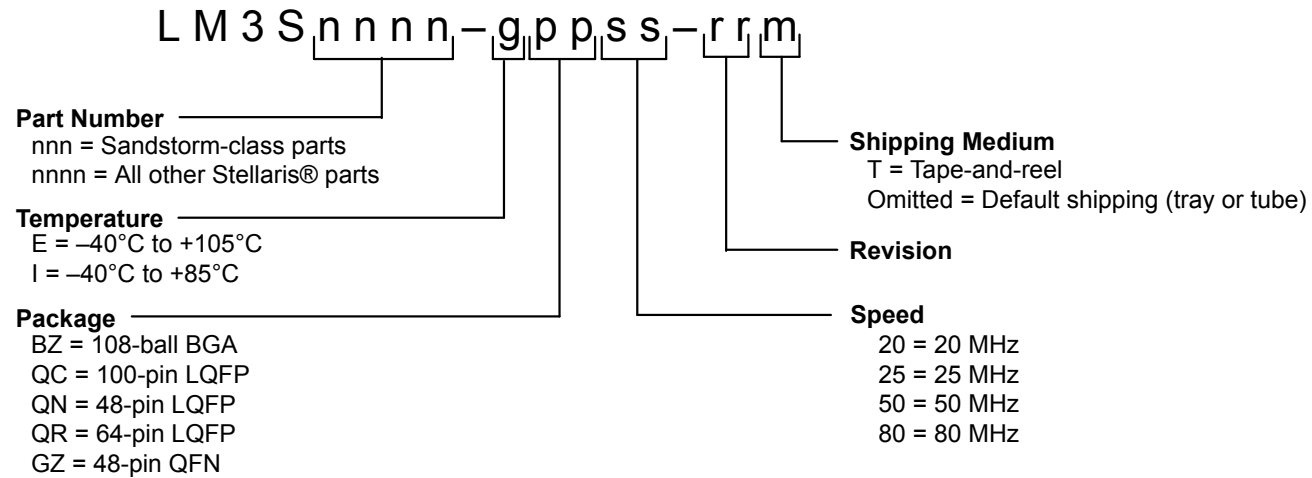

IMPORTANT NOTICE

Texas Instruments Incorporated and its subsidiaries (TI) reserve the right to make corrections, modifications, enhancements, improvements, and other changes to its products and services at any time and to discontinue any product or service without notice. Customers should obtain the latest relevant information before placing orders and should verify that such information is current and complete. All products are sold subject to TI's terms and conditions of sale supplied at the time of order acknowledgment.

TI warrants performance of its hardware products to the specifications applicable at the time of sale in accordance with TI's standard warranty. Testing and other quality control techniques are used to the extent TI deems necessary to support this warranty. Except where mandated by government requirements, testing of all parameters of each product is not necessarily performed.

TI assumes no liability for applications assistance or customer product design. Customers are responsible for their products and applications using TI components. To minimize the risks associated with customer products and applications, customers should provide adequate design and operating safeguards.

TI does not warrant or represent that any license, either express or implied, is granted under any TI patent right, copyright, mask work right, or other TI intellectual property right relating to any combination, machine, or process in which TI products or services are used. Information published by TI regarding third-party products or services does not constitute a license from TI to use such products or services or a warranty or endorsement thereof. Use of such information may require a license from a third party under the patents or other intellectual property of the third party, or a license from TI under the patents or other intellectual property of TI.

Reproduction of TI information in TI data books or data sheets is permissible only if reproduction is without alteration and is accompanied by all associated warranties, conditions, limitations, and notices. Reproduction of this information with alteration is an unfair and deceptive business practice. TI is not responsible or liable for such altered documentation. Information of third parties may be subject to additional restrictions.

Resale of TI products or services with statements different from or beyond the parameters stated by TI for that product or service voids all express and any implied warranties for the associated TI product or service and is an unfair and deceptive business practice. TI is not responsible or liable for any such statements.

TI products are not authorized for use in safety-critical applications (such as life support) where a failure of the TI product would reasonably be expected to cause severe personal injury or death, unless officers of the parties have executed an agreement specifically governing such use. Buyers represent that they have all necessary expertise in the safety and regulatory ramifications of their applications, and acknowledge and agree that they are solely responsible for all legal, regulatory and safety-related requirements concerning their products and any use of TI products in such safety-critical applications, notwithstanding any applications-related information or support that may be provided by TI. Further, Buyers must fully indemnify TI and its representatives against any damages arising out of the use of TI products in such safety-critical applications.

TI products are neither designed nor intended for use in military/aerospace applications or environments unless the TI products are specifically designated by TI as military-grade or "enhanced plastic." Only products designated by TI as military-grade meet military specifications. Buyers acknowledge and agree that any such use of TI products which TI has not designated as military-grade is solely at the Buyer's risk, and that they are solely responsible for compliance with all legal and regulatory requirements in connection with such use.

TI products are neither designed nor intended for use in automotive applications or environments unless the specific TI products are designated by TI as compliant with ISO/TS 16949 requirements. Buyers acknowledge and agree that, if they use any non-designated products in automotive applications, TI will not be responsible for any failure to meet such requirements.

Following are URLs where you can obtain information on other Texas Instruments products and application solutions:

Products

Audio	www.ti.com/audio
Amplifiers	amplifier.ti.com
Data Converters	dataconverter.ti.com
DLP® Products	www.dlp.com
DSP	dsp.ti.com
Clocks and Timers	www.ti.com/clocks
Interface	interface.ti.com
Logic	logic.ti.com
Power Mgmt	power.ti.com
Microcontrollers	microcontroller.ti.com
RFID	www.ti-rfid.com
RF/IF and ZigBee® Solutions	www.ti.com/lprf

Applications

Communications and Telecom	www.ti.com/communications
Computers and Peripherals	www.ti.com/computers
Consumer Electronics	www.ti.com/consumer-apps
Energy and Lighting	www.ti.com/energy
Industrial	www.ti.com/industrial
Medical	www.ti.com/medical
Security	www.ti.com/security
Space, Avionics and Defense	www.ti.com/space-avionics-defense
Transportation and Automotive	www.ti.com/automotive
Video and Imaging	www.ti.com/video
Wireless	www.ti.com/wireless-apps

TI E2E Community Home Page

e2e.ti.com

Mailing Address: Texas Instruments, Post Office Box 655303, Dallas, Texas 75265
Copyright © 2011, Texas Instruments Incorporated